



French Immersion Open House



Le 1e mars 2023

Welcome!

Opening prayer - Will be led by Mme Letourneau

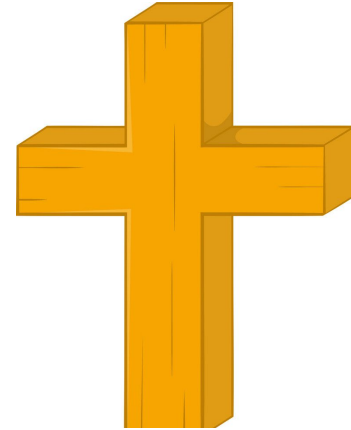

Current Program Teachers

Madame Madeleine Escobar :
Mathématiques 10C, 20-1, 30-1

Madame Meagan McQuay :
Études sociales 10-1/10-2, 20-1/20-2, 30-1/30-2

Monsieur Joel Pelletier : Sciences 10, Études
religieuses 15 & 25 , Carrière et vie

Madame Sara Lambert : French Language Arts
10-1/10-2, 20-1/20-2, 30-1/30-2, Carrière et vie



French Immersion benefits

- Maintain and extend French skills
- Develop thinking skills
- Valuable resource for future workplace or postsecondary opportunities
- Increase global mobility
- Finish what has been started
- Scholarship opportunities



French Immersion benefits at Notre Dame



- Cultural activities
- DELF
- Provides opportunity for international travel
- Opens doors
- Completes something you started
- French as a Second Language (FSL) course challenge exam



High school and Program Credit Requirements

High School Diploma

105 credits
English at 30 level
Social at 30 level
10 credits in any other 30 level course
Math at 20 level
Science at 20 level
RS 15, 25, 35
CALM 20
PE 10 (3 or 5 credit)
10 credits from either or in combination of CTS, other languages, PE (other than PE 10), Fine Arts, and Locally developed courses

French Immersion School Awarded Certificate

French Language Arts 10-1/10-2, 20-1/20-2, 30-1/30-2
Études sociales 10-1/10-2, 20-1/20-2, 30-1/30-2
Études religieuses 15, 25
Sciences 10
Mathématiques 10C, 20-1, 30-1
Carrière et vie

****Exceptions are infrequent.****

Recommendations

- Notre Dame will follow the recommendations given to us by the grade 9 teachers



Mathématiques

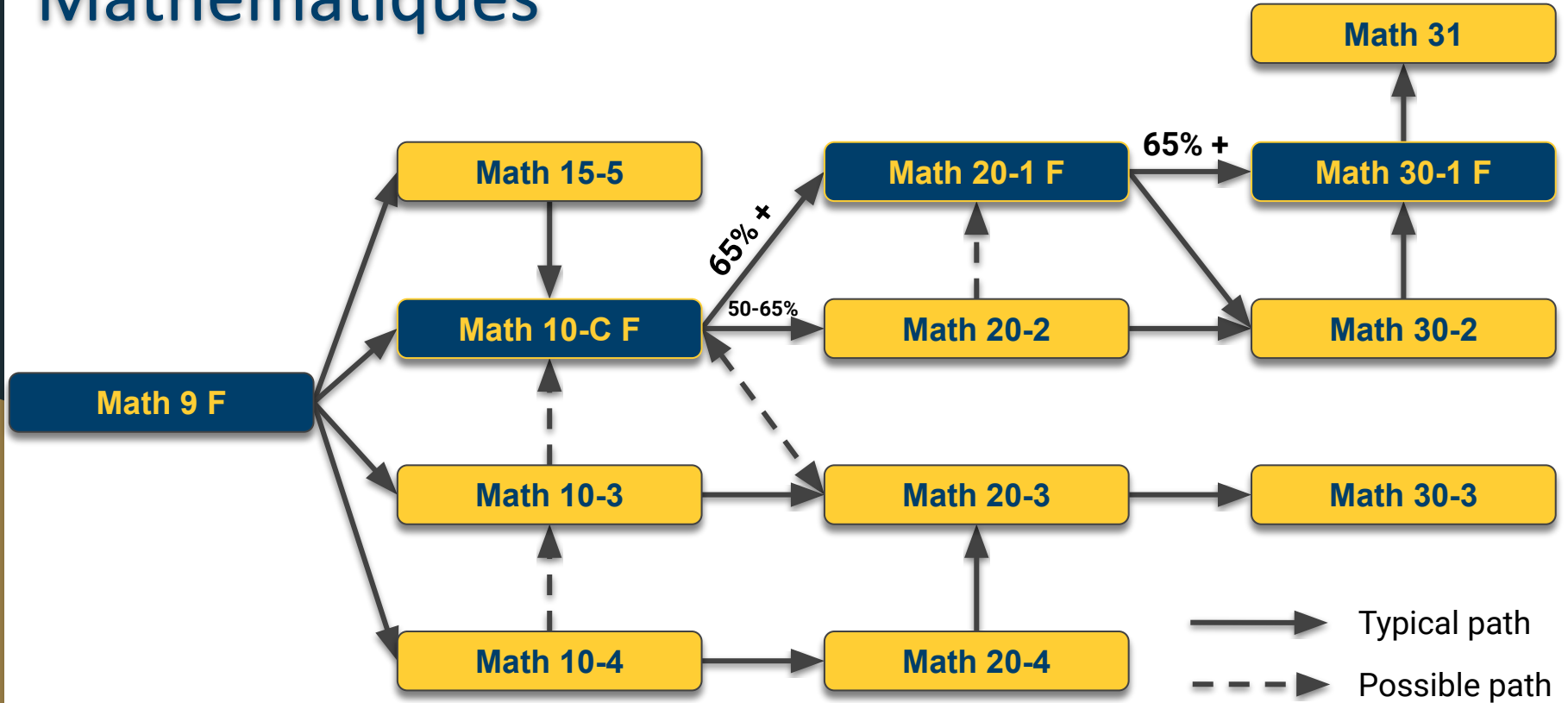

Études Sociales

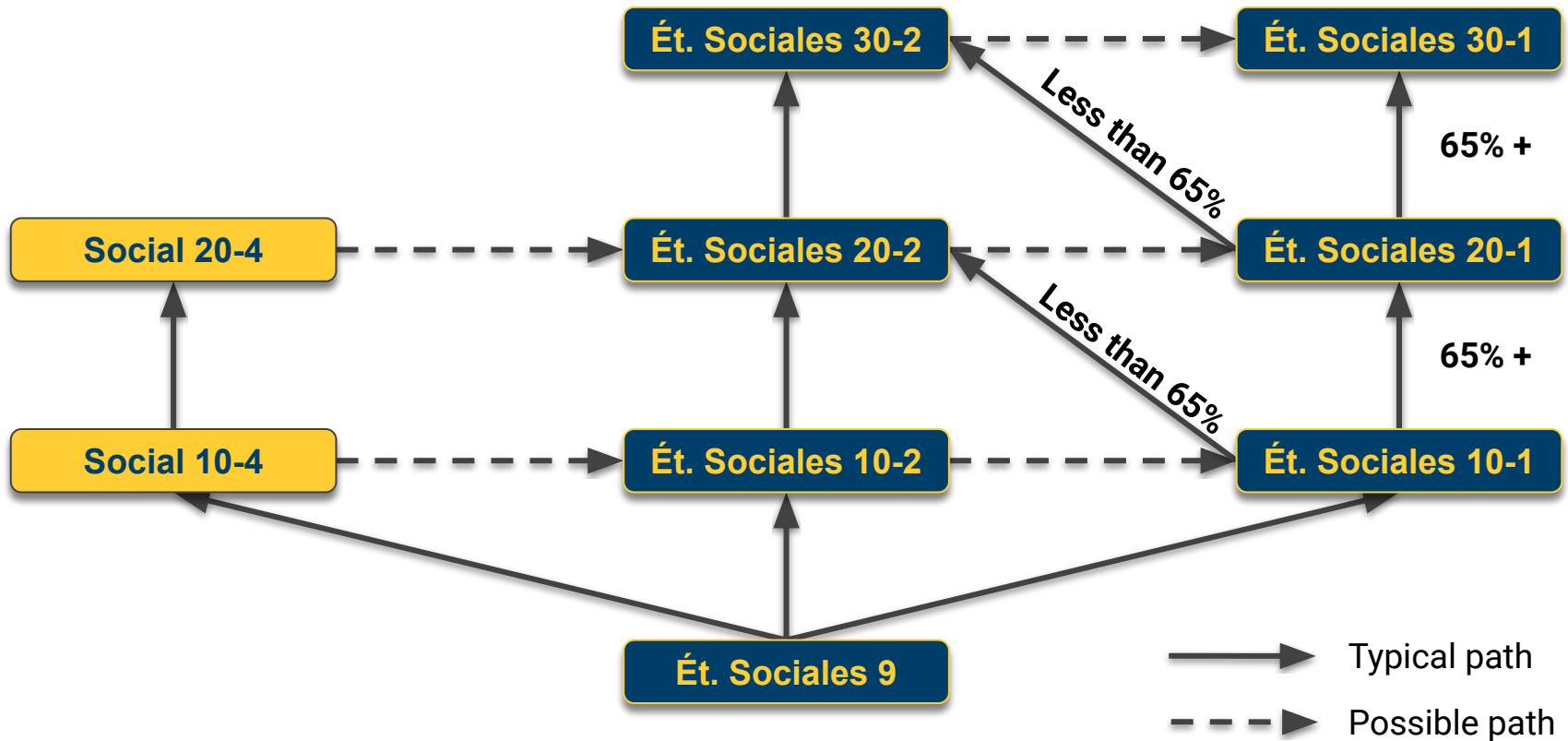

Sciences

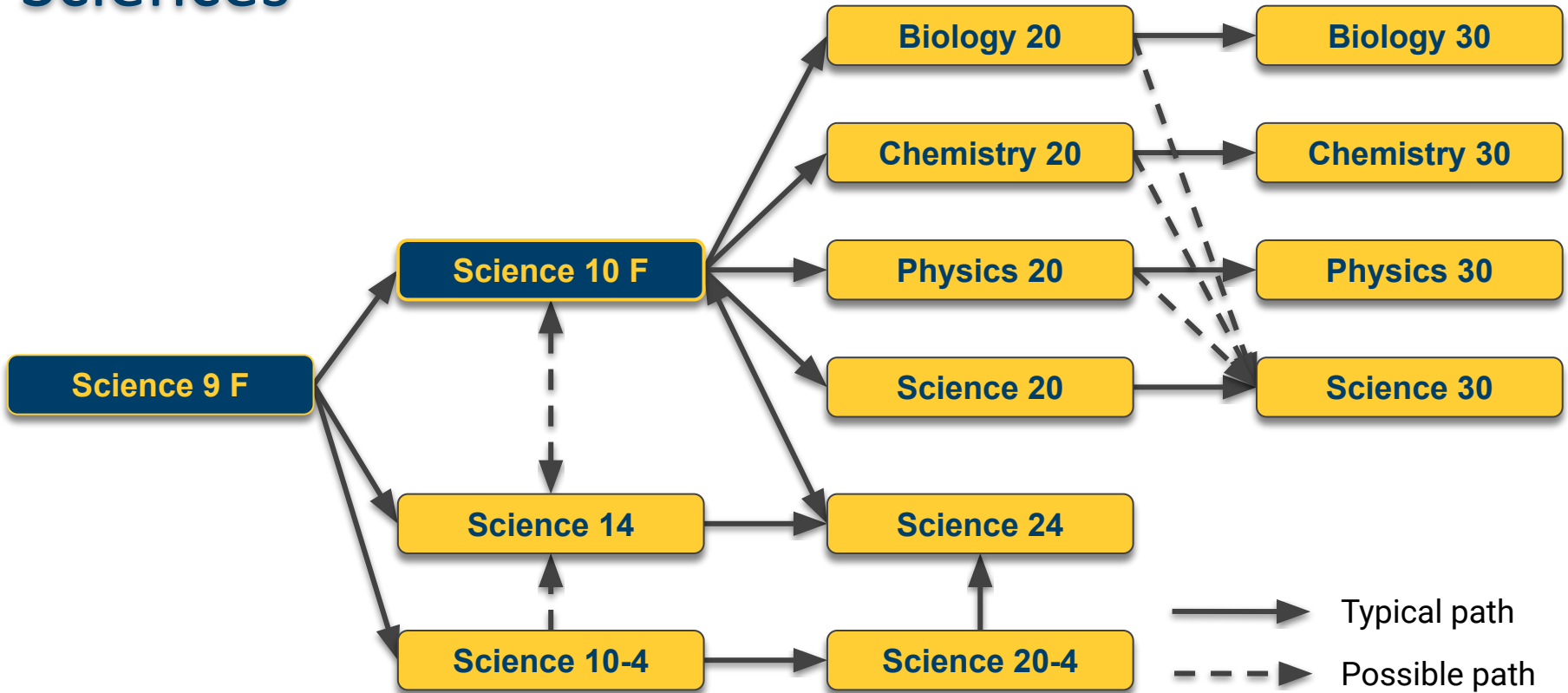

French Language Arts

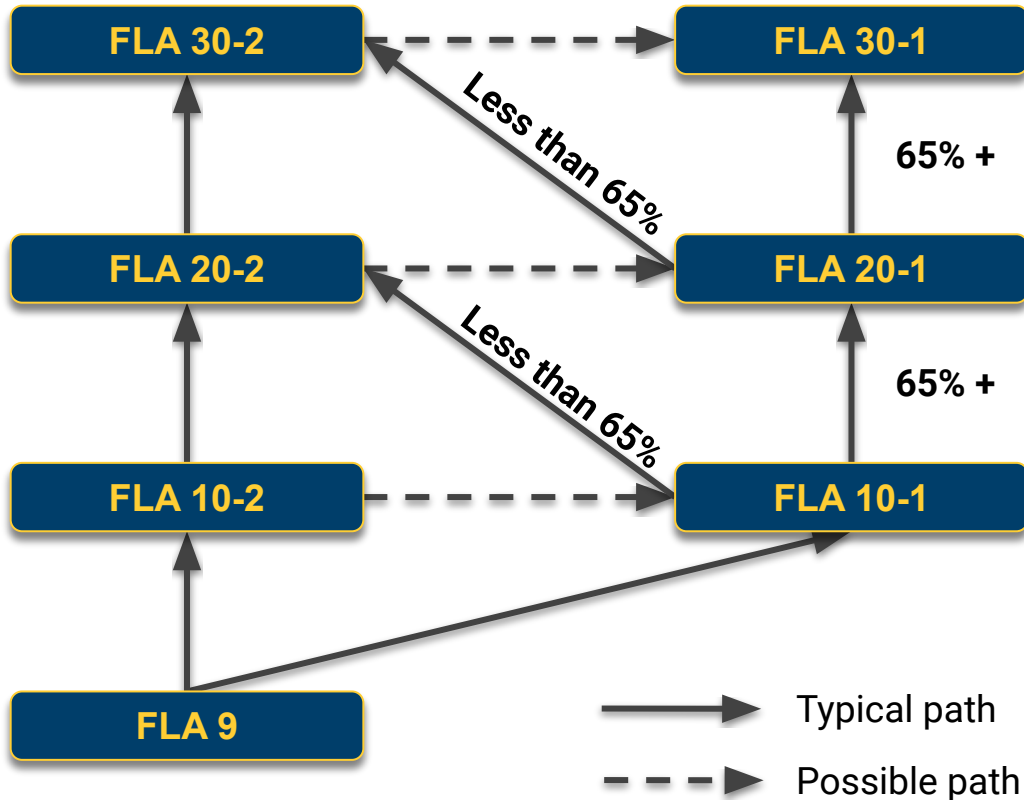

English Language Arts

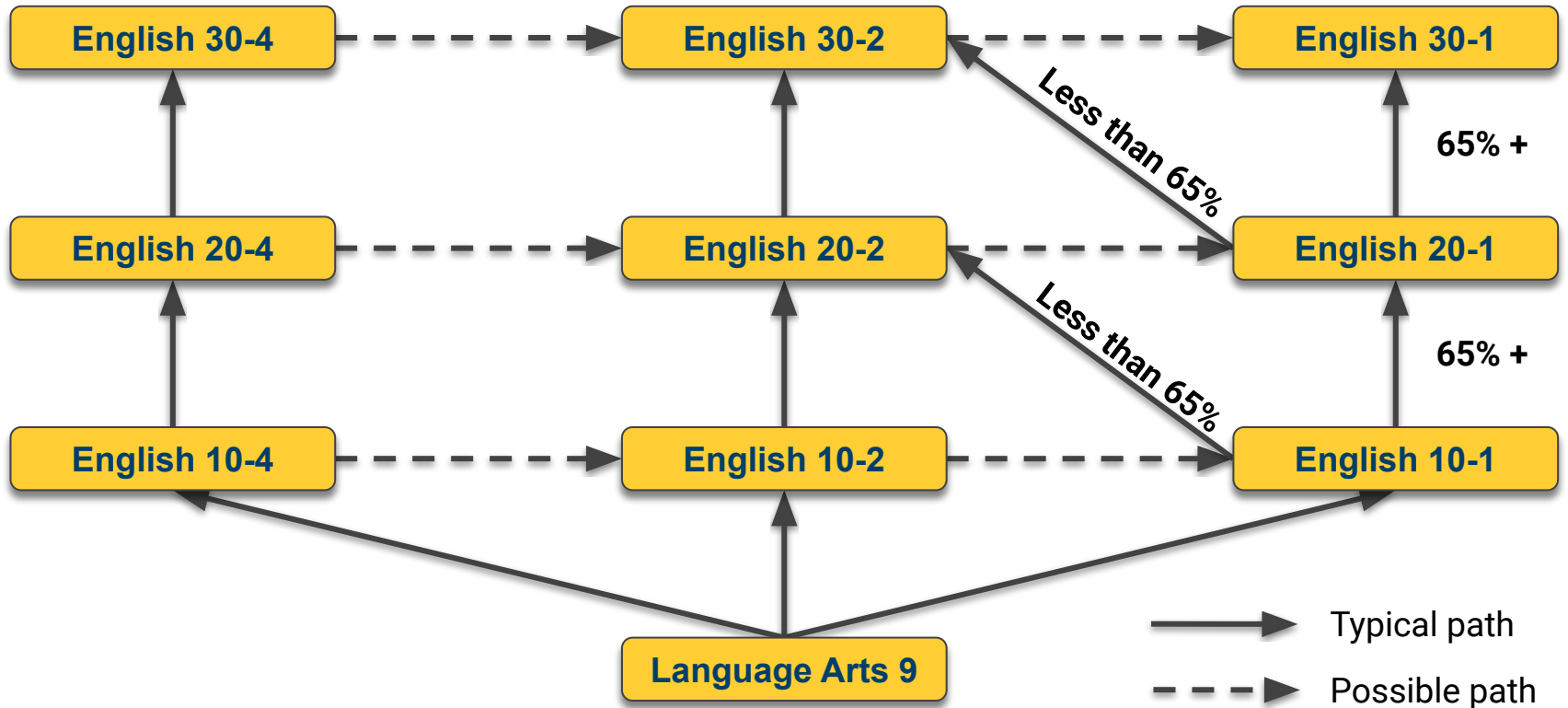

Other Courses

**RS: Roman
Catholic 35-3**

**RS: Roman
Catholic 25-3
French**

**RS: Roman
Catholic 15-3
French**

RS: Roman
Catholic courses
can be taken out
of order.

**Carriere et Vie
(Grade 11)**

Typically taken in
Grade 11.

We asked what our students what they felt were benefits to being in our program

- We already know everyone.
- We have a family-like community.
- French Immersion gives us the opportunity to speak and practice another language.
- French Immersion is going to help me get more scholarships.
- I think we learn more because we have to work harder.
- Being in French Immersion helped me learn Spanish.
- The teachers know us really well.
- We're always in class with our friends.
- Somehow it's comfortable, yet challenging.

PRIZES

Important Dates

- High School 101 - March 14th, 2023 @ 7pm @ ND
- First day of Grade 10 - August 31, 2023





Questions?



Contact information

Ike Hanna, Principal
ike.hanna@rdcrs.ca

Josh Keith, Vice Principal, Grade 10
josh.keith@rdcrs.ca

Curtis Lansing, Vice Principal, Grade 11
curtis.lansing@rdcrs.ca

Vanessa Letourneau, Vice Principal, Grade 12
vanessa.letourneau@rdcrs.ca

Sara Lambert, French Immersion Department Head
sara.lambert@rdcrs.ca

École Secondaire Notre Dame High School
notredamehigh.ca
403-342-4800

